

BLP-100 BMF 1.1 inch Digital Fingerprint Sensor

DATA SHEET

March, 2004

Specification

• Pixels	256 × 384	[H × V (dot)]
• Window size	16.0 × 23.4	[H × V (mm)]
• Picture size	1.1	[Diagonal (inch)]
• Dot arrangement	Square	
• Dot pitch	0.058 × 0.058	[H × V (mm)]
• Panel external size	24.4 × 35.9 × 1.9	[H × V × W (mm)]
• Weight	3.0	[(g)]
• Operating voltage	12.0	[(V) VDD=12V ± 0.5 ^{*1}]

Feature

- The world's first pressure sensitive fingerprint sensor
- The world's largest sensing area as a thin-shaped sensor
- No influence in the water and drying at the sensing time
- ID code function^{*2}
- Sensor check function^{*2}
- Human check device BHC-100 I/F^{*3}
- Quite low consumed electric current (sensing time peak below 3mA)
- Easy handling

Applications

Applications using BMF fingerprint sensor.

- M-commerce
- Cellular phone
- PDA
- IT-security (keyboard, mouse...etc)
- Access control
- Automotive
- Stamp verification
- Signature verification ...etc

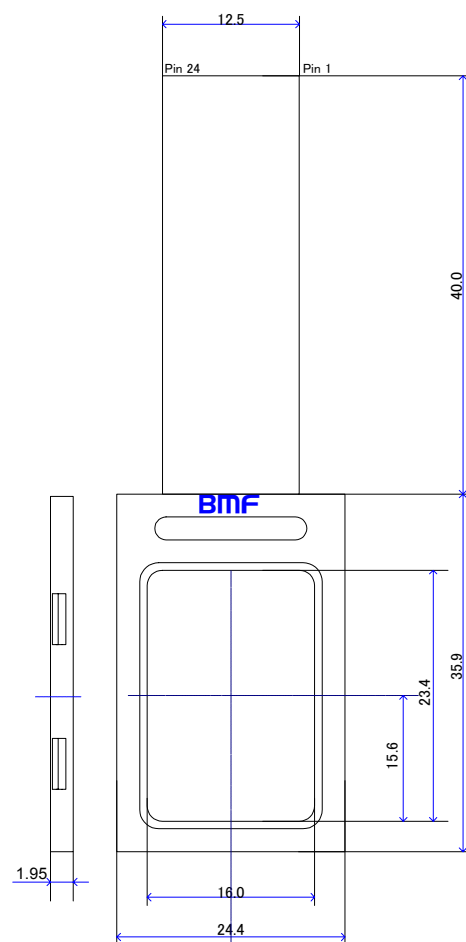

BLP-100 is the world's first pressure sensitive fingerprint sensor. Unlike other sensors in the market, it allows you to clearly sense both dry and wet fingers. It also has the largest sensing area, which enables you to capture a complete fingerprint for higher accuracy of recognition or authentication. Low power consumption is another unique feature of BMF sensor and will open the door for battery driven applications.

[Note]

^{*1}: VDD=12V use as power source for the circuit inside, ID code, human body inspection and the other.

^{*2}: Support with BMF sensor controller.

^{*3}: BHC-100 is human body inspection IC.

Electrical Characteristics

Operating condition (VSS=0V, Ta=25°C): 12V ± 0.5V

Power consumption

Ta=25°C, 12V

Parameter	Min	Typ	Max	Unit
Power consumption	-	25	40	mW

Absolute maximum rating

VSS=0V, Ta=25°C

Parameter	Rating	Unit
H/V-driver power source voltage	-1.0 ~ +14.0	V
H/V-driver Input/output pin voltage	-1.0 ~ +14.0	V
Signal detection pin voltage	-1.0 ~ +13.0	V

Electrical characteristics

VSS=0V, Ta=25°C

Parameter	Min	Typ	Max	Unit	
H/V-driver	Low	-0.3	0.0	0.3	V
Input pin voltage	High	2.5	3.0	4.0	V
Signal detection pin voltage range	0.0	-	3.0	V	

System Configuration

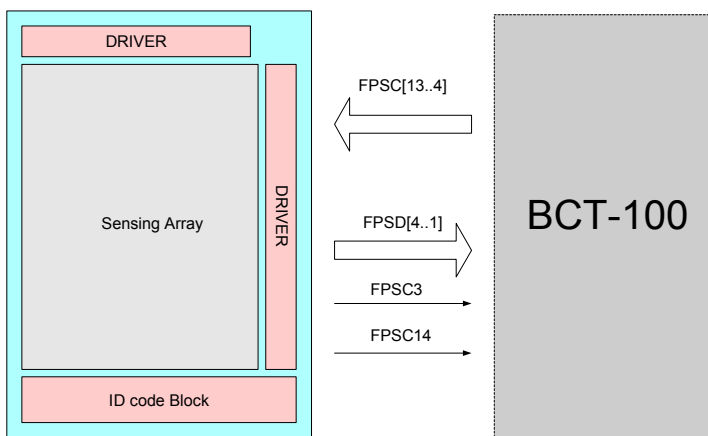

Pin Function Descriptions

Pin Number	Name	Note
1	NC	Open
2	FPSC1	Connected to Ground with 10KΩ Register
3	FPSC2	Connected to Ground
4	FPSD1	Connected to the same name Pin of the BCT-100
5	FPSD2	Connected to the same name Pin of the BCT-100
6	FPSD3	Connected to the same name Pin of the BCT-100
7	FPSD4	Connected to the same name Pin of the BCT-100
8	VDD	Power Supply (+12V)
9	FPSC3	Connected to the same name Pin of the BCT-100
10	FPSC4	Connected to the same name Pin of the BCT-100
11	FPSC5	Connected to the same name Pin of the BCT-100
12	FPSC6	Connected to the same name Pin of the BCT-100
13	FPSC7	Connected to the same name Pin of the BCT-100
14	VSS	Connected to Ground
15	FPSC8	Connected to the same name Pin of the BCT-100
16	FPSC9	Connected to the same name Pin of the BCT-100
17	VDD	Power Supply (+12V)
18	FPSC10	Connected to the same name Pin of the BCT-100
19	FPSC11	Connected to the same name Pin of the BCT-100
20	FPSC12	Connected to the same name Pin of the BCT-100
21	FPSC13	Connected to the same name Pin of the BCT-100
22	VSS	Connected to Ground
23	FPSC14	Connected to the same name Pin of the BCT-100
24	NC	Open